

# Battery Backup Kit

## EASYROLLER GDO-6AM Wiring and Installation Instructions

### BATTERY BACKUP PACK GDO-6AM SAP# ORDER NO. 87992

	DESCRIPTION	QTY
①	BATTERY PACK	1
②	BATTERY HARNESS	1
③	TAPTITE "P" M3.5X 8 SCREWS	2
④	PLASTER WALL PLUGS	2

	DESCRIPTION	QTY
⑤	SBC-02 CHARGER HARNESS EXT	1
⑥	CABLE CLAMP ACC-1.5 (3/16")	1
⑦	CHARGER BOARD SBC-02	1
⑧	SBC-02 CHARGER HARNESS	1

	DESCRIPTION	QTY
⑨	SBY-2 BATTERY HARNESS	1
⑩	TAPTITE SCREW "P" M4x8	4
⑪	TAPTITE SCREW "P" M4x10	2
⑫	CABLE CLAMP ACC-1.5 (3/16")	1

#### SPECIFICATIONS

APPROXIMATE NUMBER OF CYCLES UNDER BATTERY POWER	10
AVERAGE CYCLE TIME UNDER BATTERY POWER (OPENING AND CLOSING)	40 SECS
BATTERY CAPACITY (AMP HOURS)	1.3 AH
TIME FOR RE-CHARGE	24 HOURS

#### WARRANTY

1 year

This warranty is to be read in conjunction with the owner's copy of the opener installation instruction.



### WARNING!

- Disconnect the power cord from mains before connecting or disconnecting the battery box, or making any repairs, or removing covers.
- Servicing of batteries should be performed or supervised by personnel knowledgeable about batteries and the required precautions.
- When replacing batteries, replace with the same type and number of batteries or batteries packs.
- DO NOT short the output of batteries. Serious personal injury and/or property damage can result from failure to follow this warning.
- During charging and discharging cycles the lead-acid batteries may release explosive gases. Ensure that the area around the batteries is well ventilated.
- Take care not to allow any metal objects to make contact with the positive and negative terminals. This short circuit may cause sparks battery and possible damage to the battery, or even cause an explosion.

- The battery box unit should be installed away from sprinkler systems.
- DO NOT immerse in water or spray directly with a hose or other device.

- DO NOT dispose of batteries in a fire. The batteries may explode.
- The battery backup box contains sealed lead-acid batteries that must be disposed of properly at the end of their useful life.
- DO NOT open or mutilate batteries. Released electrolyte is harmful to the skin and eyes. It may be toxic.
- Be careful on the ladder. Practice correct lifting techniques.
- Ensure ladder is the correct type for job.
- Ensure ladder is on flat ground.
- DO NOT handle damaged or leaking batteries
- Wear appropriate protective clothing, use protective glasses and avoid touching your face and eyes after working with batteries.



### AVERTISSEMENT!

- Débrancher le cordon d'alimentation à partir de prise de courant avant de connecter ou de déconnecter la boîte de la batterie, ou d'effectuer toute réparation, ou d'enlever des couvercles.
- Entretien des batteries doit être effectué ou supervisé par du personnel compétent au sujet de batteries et les précautions requises.
- Lors du remplacement des batteries, remplacer par le même type et le nombre de des batteries ou des batteries packs.
- NE PAS COURT la sortie des batteries. De sérieuses blessures et / ou des dommages matériels peuvent résulter du non-respect de cet avertissement.
- Durant les cycles de charge et de décharge des batteries plomb-acide peuvent libérer des gaz explosifs. Veiller à ce que la zone autour des batteries est bien ventilée.
- Prenez soin de ne pas laisser des objets métalliques à établir un contact avec les bornes positives et négatives. Ce court-circuit peut provoquer des étincelles batterie et de possibles dommages à la batterie, ou même provoquer une explosion.

- L'unité de boîte de la batterie doit être installé loin des systèmes de gicleurs.
- NE PAS immerger dans l'eau ou pulvériser directement avec un tuyau ou un autre dispositif.

- NE PAS jetez batteries dans un feu. Les batteries peuvent exploser.
- La boîte de batterie de secours contient des batteries plomb-acide scellées qui doivent être éliminés de façon appropriée à la fin de leur vie utile.
- NE PAS ouvrir ni détériorer les batteries. L'électrolyte déversé est dangereux pour la peau et les yeux. Il peut être toxique.
- Soyez prudent sur l'échelle. Pratiquer les techniques correcte de levage.
- Veiller à l'échelle est le type correct pour le travail.
- Veiller à l'échelle est sur la terre plate.
- NE PAS manipuler les batteries abîmés ou qui fuient.
- Porter un vêtement de protection approprié, utiliser des lunettes de protection et éviter de toucher votre visage et aux yeux après le travail avec des batteries.

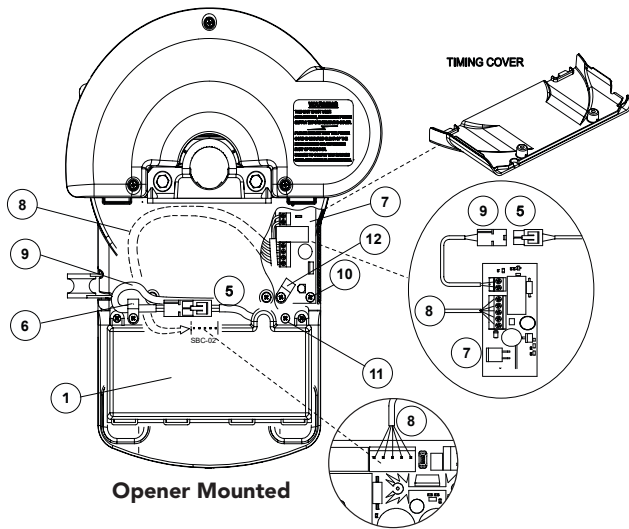

**Opener Mounted**

**Opener Mounted**

- Unplug the drive unit from mains power.
- Remove the timing cover and light diffuser.
- Mount the Charger Board (7) on the chasis and secure with four (4) Taptite 'P' M4x8 screws (10).
- Feed the battery harness (5) through the cable clamp (12) and secure left corner of the board. Feed the Wire Harness (8) around the timing assembly, through opening and plug into SBC-02 connector on the control board.
- Remove breakaway slot on timing cover and feed wire battery harness (9) through slot and replace timing cover. Secure in place with screws.
- Mount battery backup kit (1) onto support chassis and secure right side screw first (charger board side) (11).
- Position the wire battery harness (9) neatly and secure left side of battery kit with cable clamp (6).



**WARNING! After Step (h) the opener may become active (even when power is off). This is a result of a residual charge in the batteries.**  
**AVERTISSEMENT! Après l'étape (h) l'opérateur peut devenir actif (même alimentation est éteinte). Ceci est un résultat d'une charge résiduel dans les batteries.**

- Connect battery harnesses (5) and (9) together.
- Close the light diffuser and reconnect power.

**NOTE:** Batteries may take up to 48 hours to charge fully after initial installation.

- Run the Testing / Maintenance procedure to test battery.

**Troubleshooting**

Symptom	Possible cause	Remedy
Door stops or moves very slowly under battery power	Batteries may be weak or have no charge	Connect mains power and allow the batteries to charge. This may take 24 hours to reach maximum charge capacity.
	Batteries may not be connected properly.	Check wiring.
Door will not operate when mains power is disconnected.	Batteries may have no charge	Connect mains power and allow the batteries to charge. This may take 24 hours to reach maximum charge capacity.
	Faulty Batteries	Disconnect the batteries from the board. Check the voltage of the each battery. Voltage should not drop below 10V.

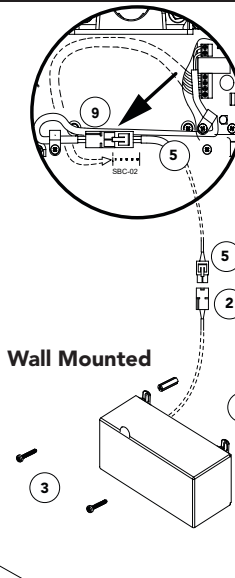

**Wall Mounted**

**Wall Mounted**

- Unplug the drive unit from mains power.
- Remove the timing cover and light diffuser.
- Mount the Charger Board (7) on the chasis and secure with four (4) Taptite 'P' M4x8 screws (10).
- Feed the battery harness (5) through the cable clamp (12) and secure left corner of the board. Feed the Wire Harness (8) around the timing assembly, through opening and plug into SBC-02 connector on the control board.
- Remove breakaway slot on timing cover and feed wire battery harness (9) through slot and replace timing cover. Secure in place with screws.
- Connect the battery harness extension (5) plug to the battery harness (9) as shown.
- Position the wire battery harness (9) neatly and secure left side of battery kit with cable clamp (6).
- To wall mount - use the battery pack as template to mark where to drill holes.

- For plaster walls - insert (2) two plaster wall plugs (4) into holes, place battery backup kit over holes and affix with (2) two Taptite "P" M3.5 x 8 screws (3).
- For brick walls - place the battery backup kit over the holes and affix with (2) two Taptite "P" M3.5 x 8 screws (3).



**WARNING! After Step (i) the opener may become active (even when power is off). This is a result of a residual charge in the batteries.**  
**AVERTISSEMENT! Après l'étape (i) l'opérateur peut devenir actif (même alimentation est éteinte). Ceci est un résultat d'une charge résiduel dans les batteries.**

- Connect battery harness (2) to the harness extension (5).
- Close the light diffuser and reconnect power.

**NOTE:** Batteries may take up to 24 hours to charge fully after initial installation.

- Run the Testing / Maintenance procedure to test battery.

**Testing / Maintenance**

To ensure a long trouble free life for your battery backup it is recommended you run the testing procedure on a monthly basis. Batteries should not need replacing for 4 - 5 years.

**Testing Procedure:**

- Press the transmitter to activate the opener.
- Whilst the door is in motion disconnect power. The door should complete the cycle as normal.
- Wait for the door to finish its travel.
- Press the transmitter to activate the opener.
- Whilst the door is in motion reconnect power. If the door stopped or moved very slowly under battery power, ensure mains power is connected for 24 hours to recharge the batteries. Test the opener again under battery power to ensure batteries are working effectively.